



EMC

ENERGY MADE CLEAN

ENGINEERING



The Booming West

Jamie Ally, General Manager – Engineering, EMC

Electricity Growth in WA

Forecast Total Electricity Consumption

(2009-2020, GWh/a)

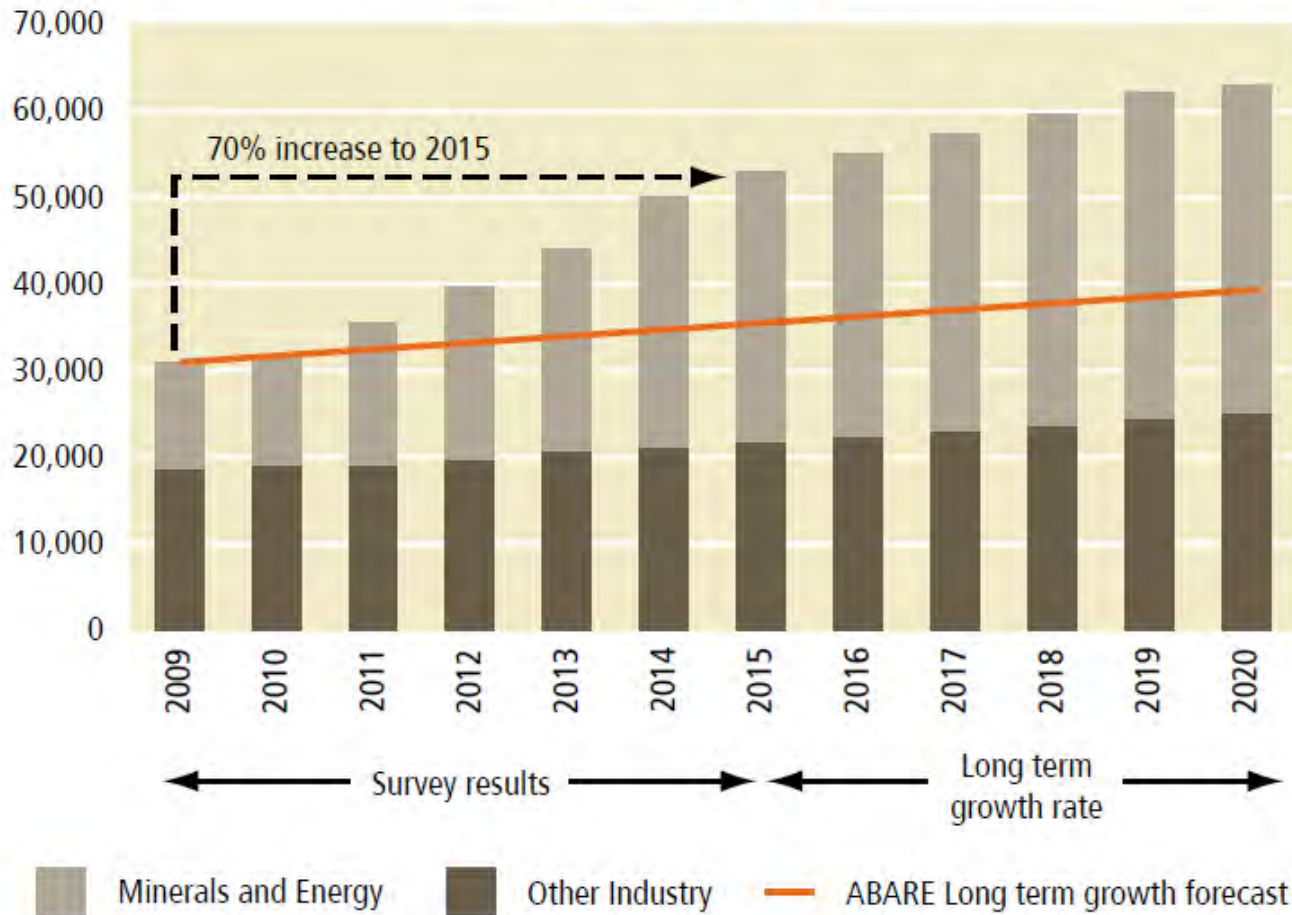

Source: State Growth Outlook study; Office of Energy; ABARE

Source: Chamber of Minerals and Energy and PwC, WA State Growth Outlook 2011, April 2011.

Minerals and energy increase

Minerals and Energy Electricity Demand (GWh/a, Incremental to 2009)

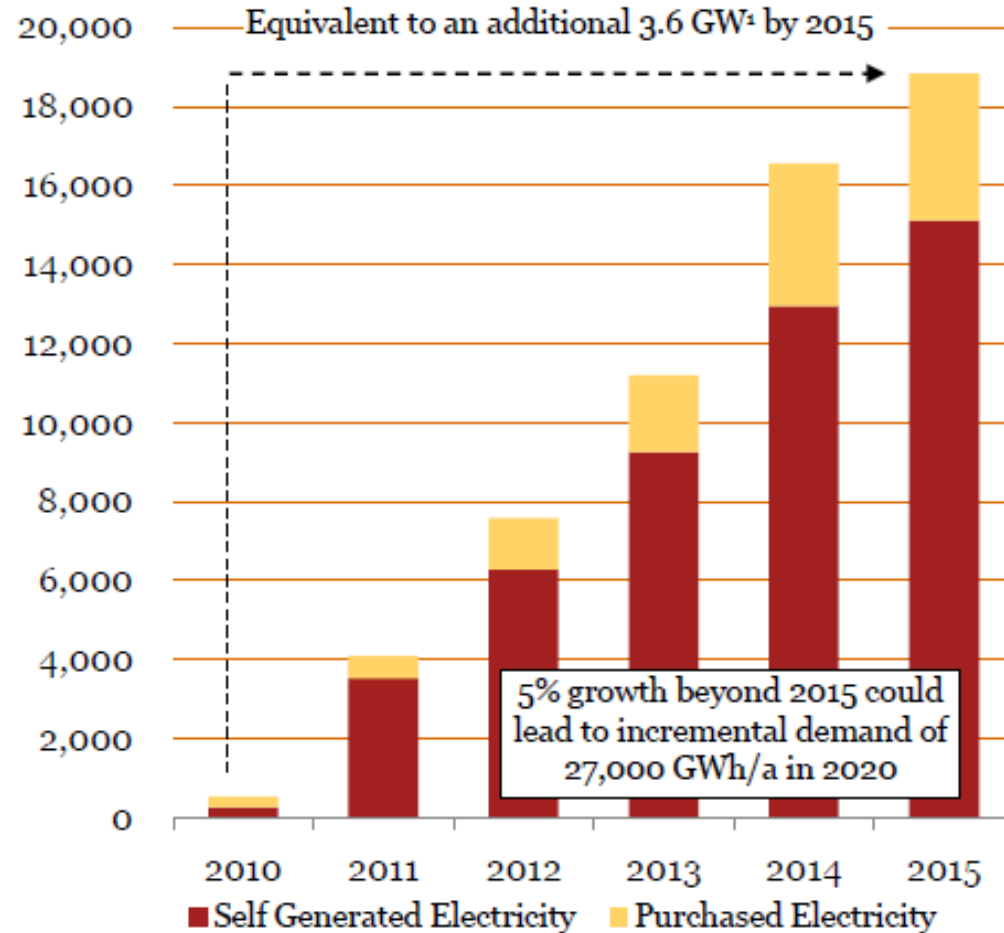

Source: Chamber of Minerals and Energy and PwC, WA State Growth Outlook 2011, April 2011.

Sources of self-generation

Source of New Self Gen Electricity
(GWh/a, Incremental to 2009, 2010-2020)

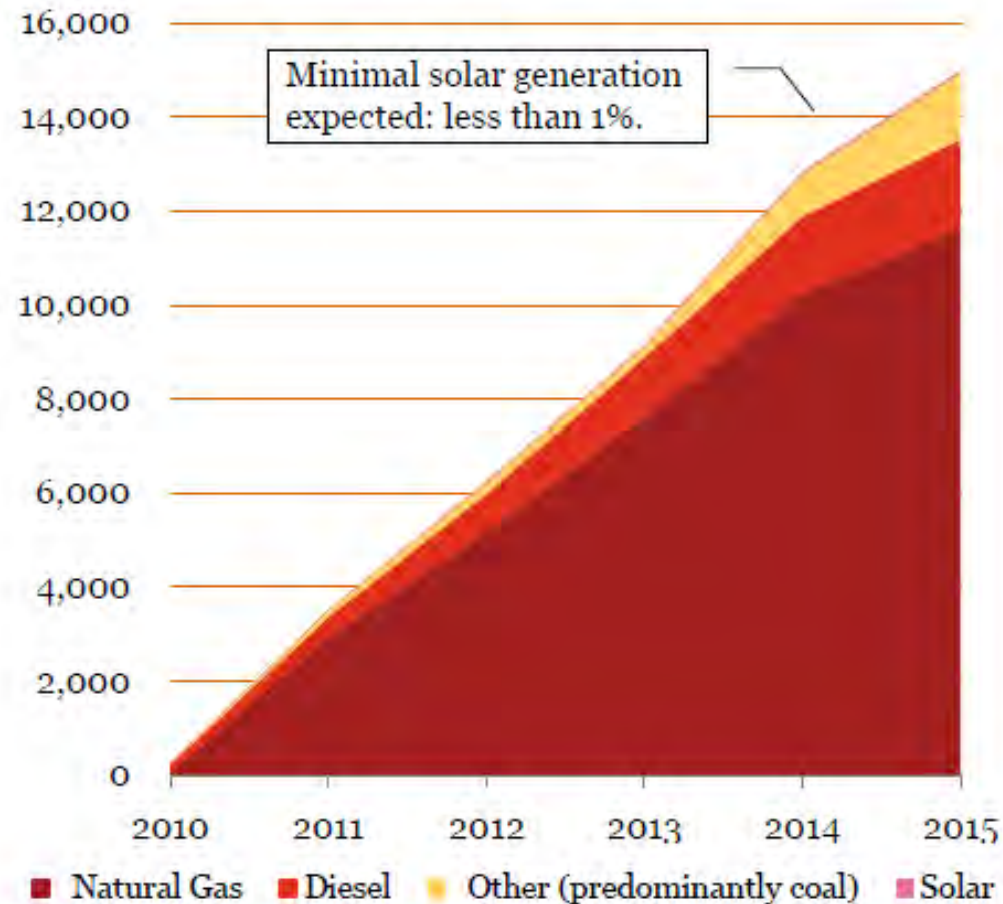

Source: Chamber of Minerals and Energy and PwC, WA State Growth Outlook 2011, April 2011.

The size of the challenge

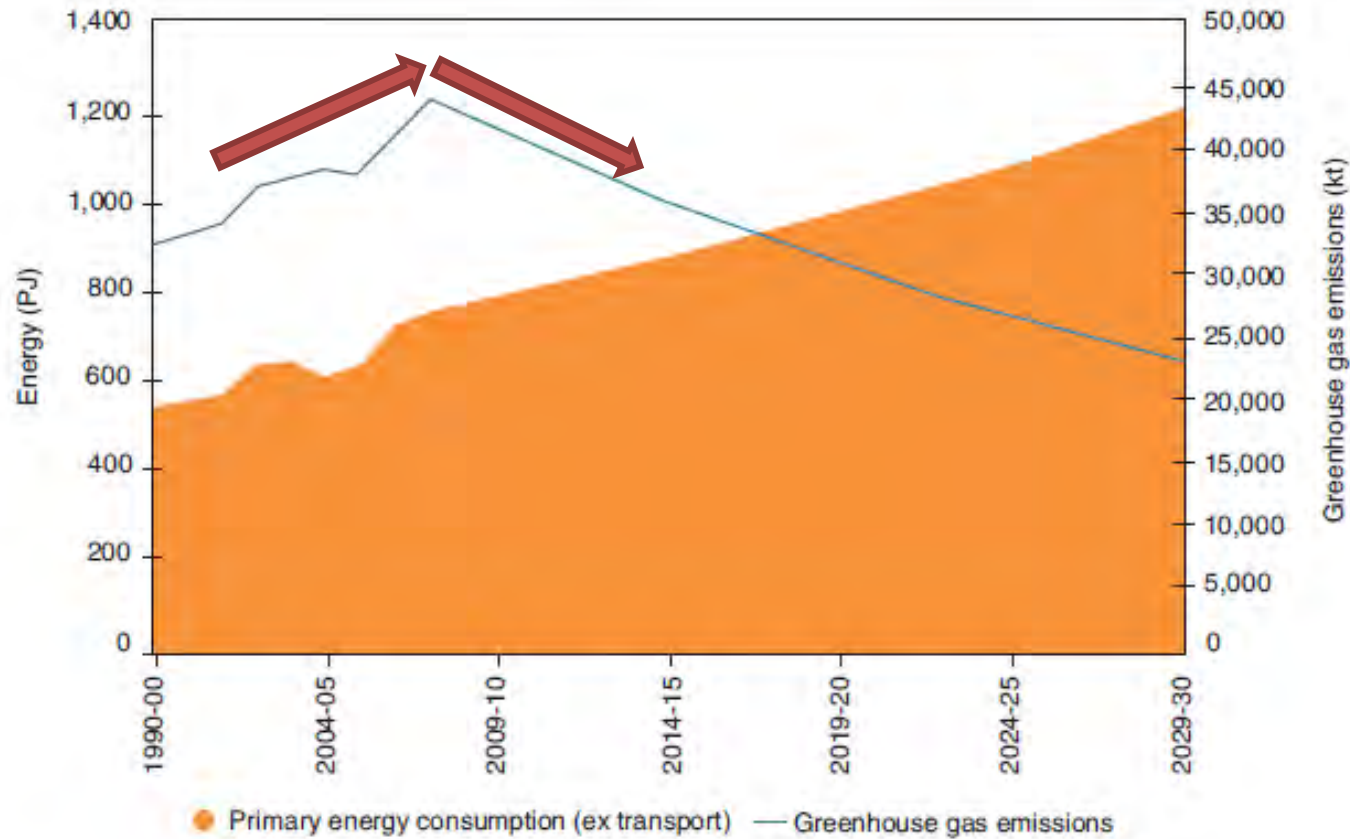

Source: ABARE

The size of the challenge

Equivalent to....

- > Eliminating emissions from all Australia's planes, trains, automobiles, plus zero emissions replacement of gas for heating and industrial production.
- > Expanding renewable energy from 10% to 75%.
- > Reforesting an area half the size of the State of Victoria

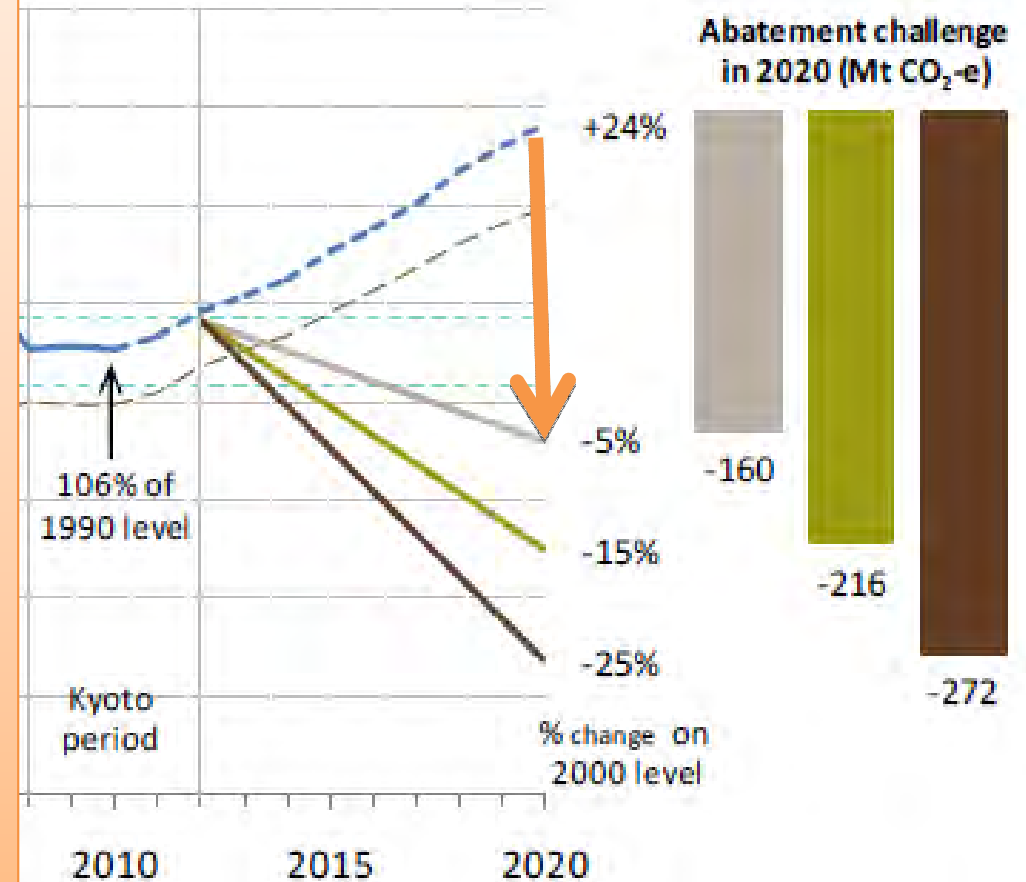

Source: Grattan Institute

The Information Gap

- We must bridge the information gap.
- Likely costs need to be established in as much detail as possible and factored into long term asset management plans.



Changes in the generation mix

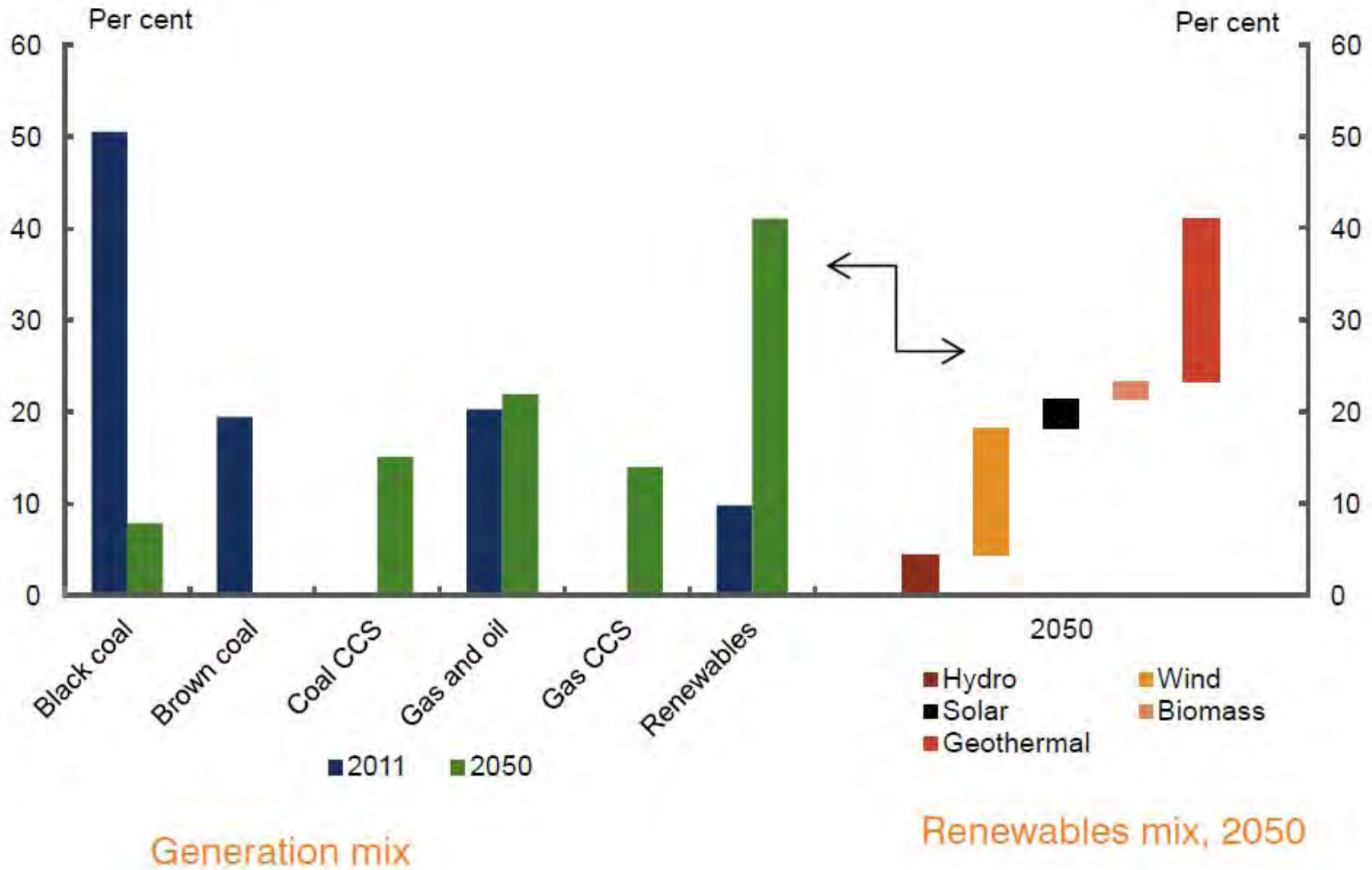

Source: The Treasury, Strong Growth, Low Pollution – Modelling a carbon price, 2011.

Greenhouse intensity of GDP

Tonne of CO₂ eq. per \$m of GDP

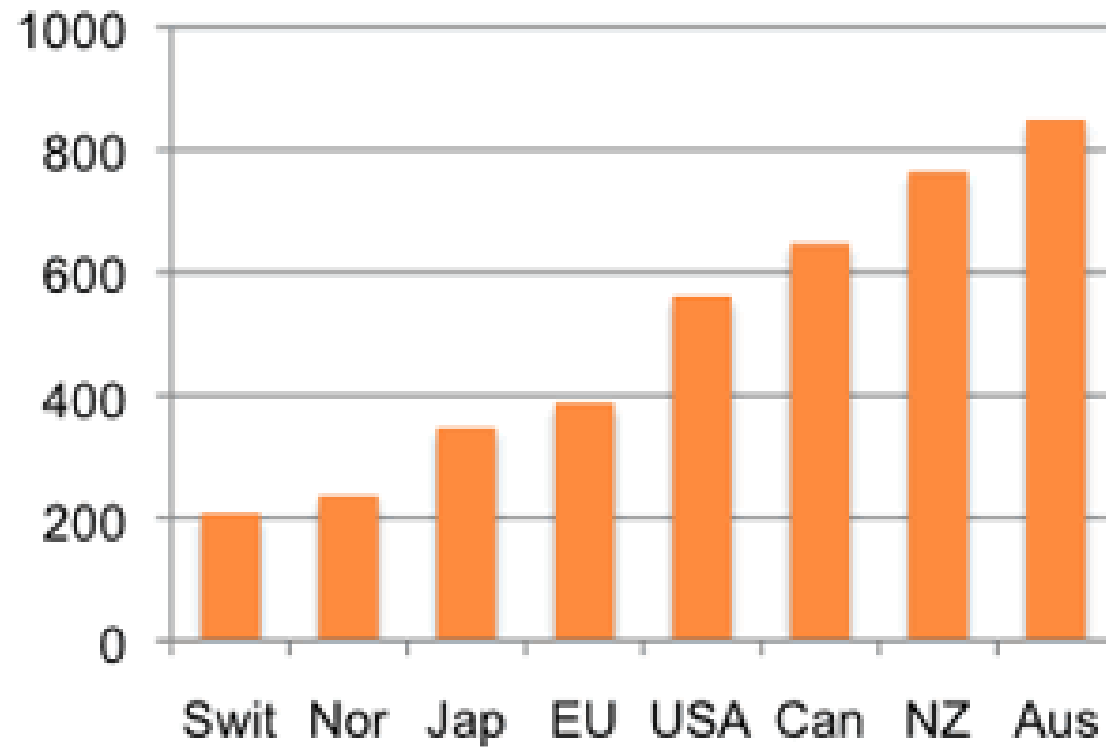

Source: Grattan Institute, 2012.

Energy intensity factors

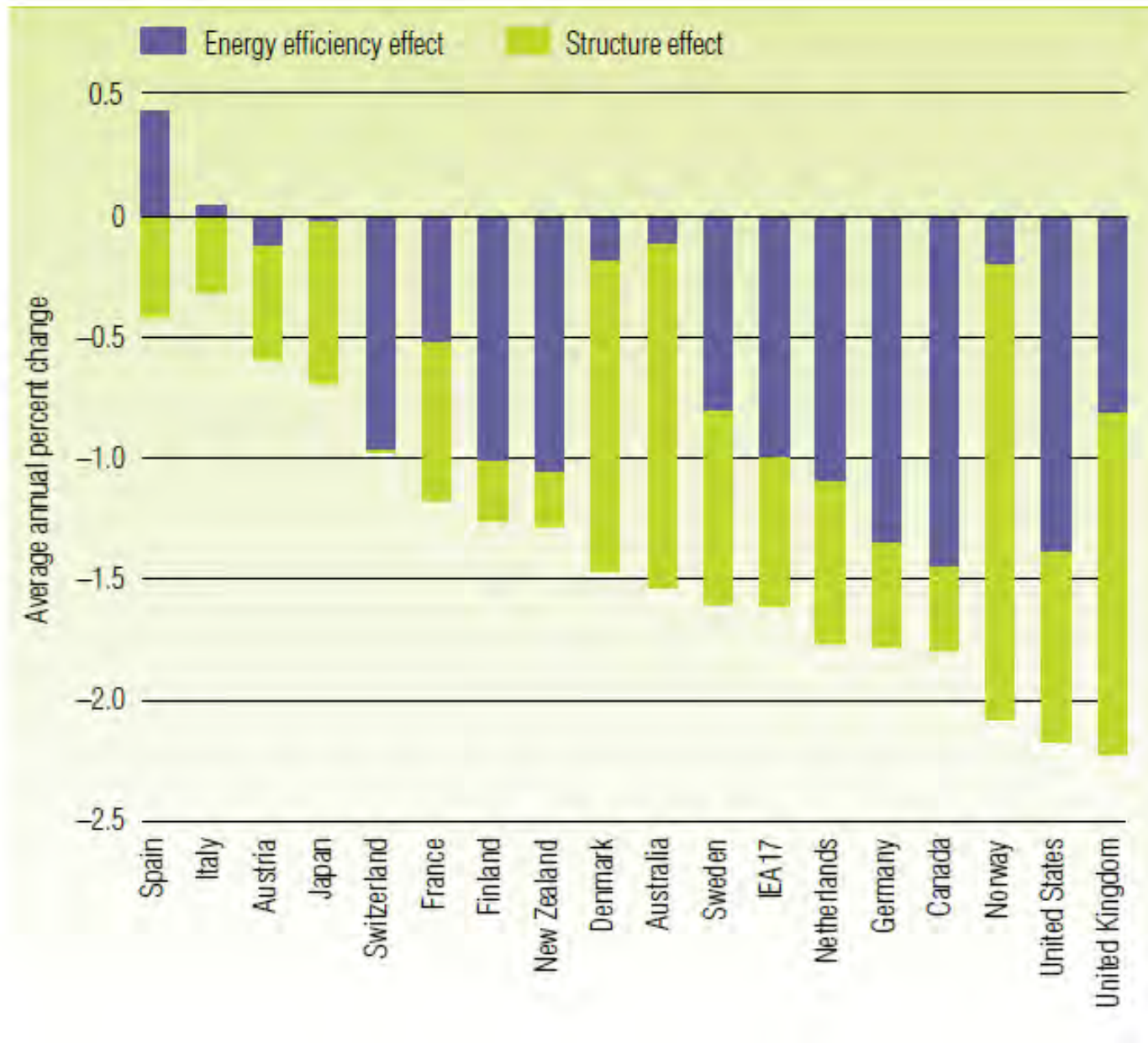

Source: Report of the Prime Minister's Task Group on Energy Efficiency, 2011.

Energy efficiency

For most organisations:

- > Energy costs as a percentage of total costs are small
- > Tariffs are escalating
- > However, energy is the primary source of GHG
- > Energy efficiency is the primary hedge



Distributed generation

Opportunities for DG

- > Reduced network costs, reduced network stress
- > Better opportunities for cogen and trigen
- > Reduce 'peakyness' of network
- > Reduced investment risk (smaller, modular)
- > Etc...

Barriers include

- > Planning and approvals complexity
- > Network connection and access costs
- > Market structure
- > Etc...

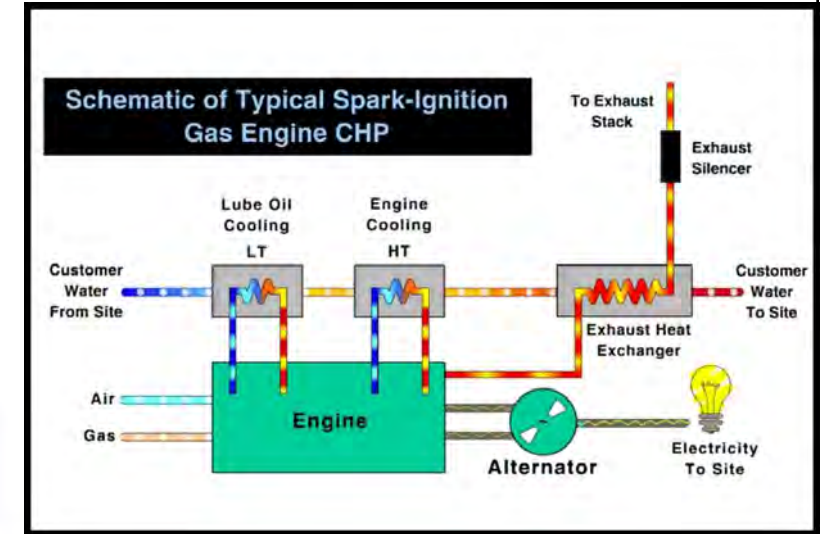

Thank you

- **Jamie Ally**
General Manager - Engineering
- jamie.ally@energymadeclean.com
- 0404 662 294



≡ Head Office	≡ Victoria	≡ Regional	≡ Regional
Perth EMC House 18 Colin St West Perth WA 6005 T 1300 558 687 I +61 8 6231 1480 F +61 8 6230 4926 E info@energymadeclean.com	Melbourne 11 Princes Street St Kilda VIC 3182 PO Box 573 Altona VIC 3018 T 1300 690 043 F +61 3 9398 6040	Kalgoorlie Suite 6 19 Cheetham Street Kalgoorlie WA 6430 T 1300 690 043	Carnarvon Research & Demonstration Facility Cnr HMAS Sydney Memorial Drive & Massey Bay Road T 0409 845 318

EMC Group

Developing and Deploying Clean Energy Solutions

www.energymadeclean.com

EPC & EPCM



Finance own and operate



Power Retail



Activity

- Fee for service
- Medium to large scale energy
- Efficiency, Cogen, Trigen
- EEO, NGRS, CleanTech grants

- Project developer
- Infrastructure ownership
- PPA's to utilities
- Financing

- Price competitive clean Power
- Unique Customer direct supply
- PPA direct (retail)

Activity

Earnings

- Developer Profit
- Consulting Profit + Cashflow

- Operator Profit + Cashflow
- Owner Profit
- Financer Profit

- Retail – W'sale margin

Earnings



Aim: License Storage Technology: India, China, Africa



Electricity prices

Electricity prices for households and businesses
quarterly index

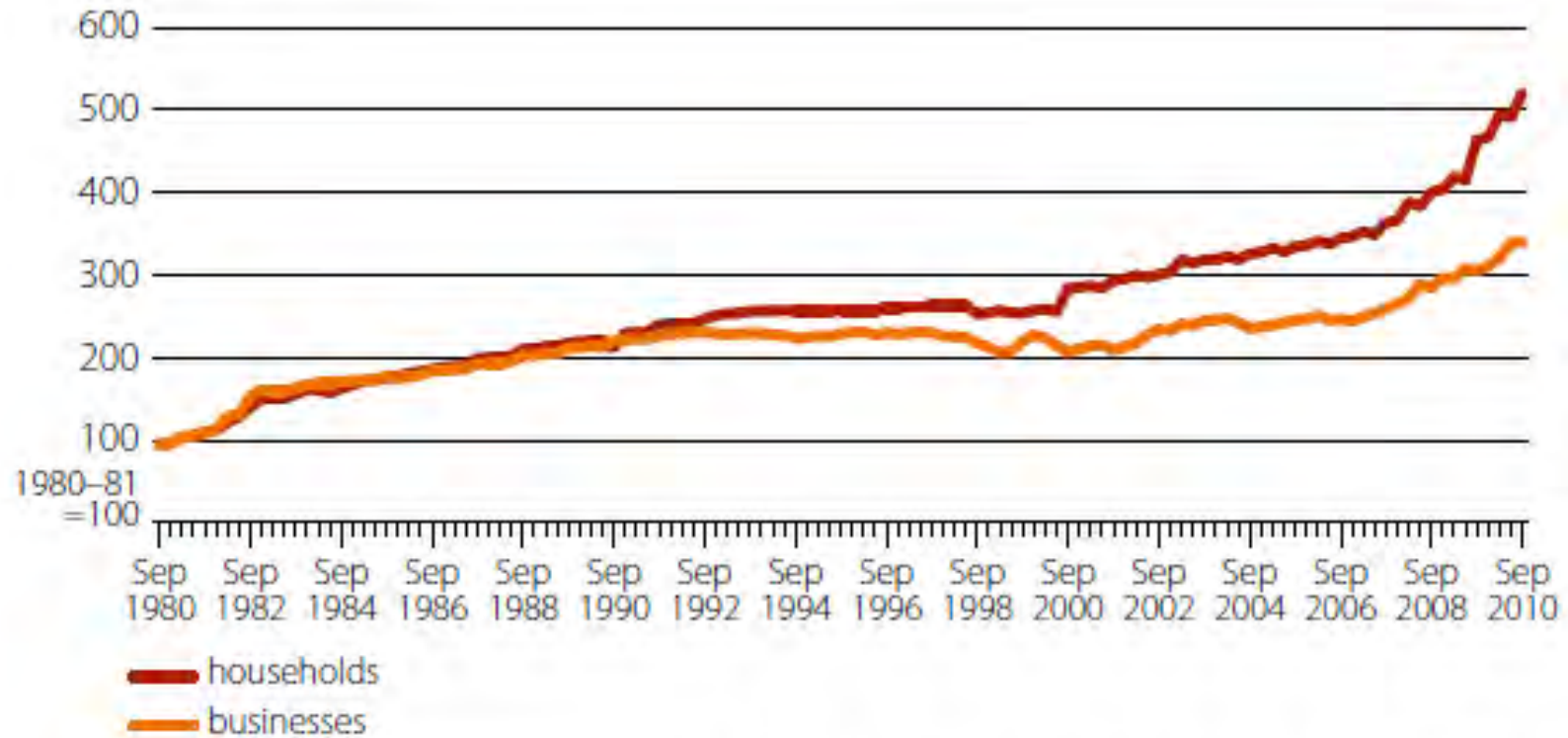

Sources: ABS, *Producer Price Indexes Australia*, cat. no. 6427.0; *Consumer Price Index Australia*, cat. no. 6401.0.

Source: Dept of Resources, Energy and Tourism, *Energy in Australia 2011*.

Electricity prices

World electricity prices, selected countries, 2009 a

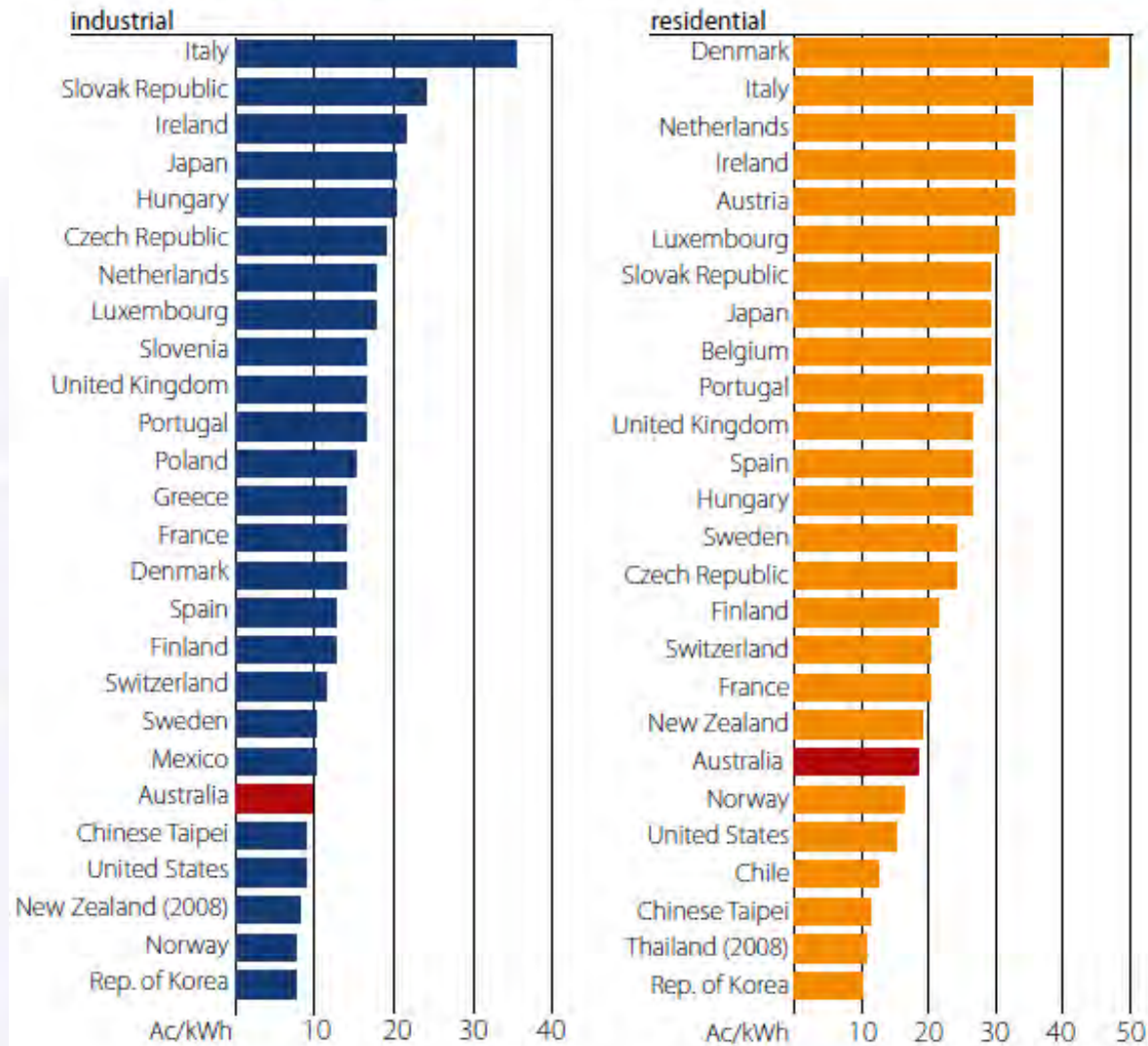

a Australian prices estimated using 2004 prices from IEA Energy Prices and Taxes, and ABS index of electricity prices for households and businesses.
Sources: IEA, Energy Prices and Taxes 2010; ABS.

